



# TEN TEC TRITON II

How to go bald in short order ~ a result of hair pulling!

## ABSTRACT

Follow along with me on how I replaced the Triton II Analog VFO system with a modern Digital Electronics counterpart. Older radios (this one is 50+ years old) can be made useful on today's bands with some low cost easily implemented digital technology. For about \$25 the Digital components can be acquired all new. A huge leverage is achieved with the Arduino code. The major effort was understanding how the Triton II was originally designed and implemented. Some of this design today seems arcane, but in 1970 it was leading edge.

Pete Juliano

In December of 2023 RTFM – it is step one!

# Ten Tec Triton II Digi-VFO & Controller

By: Pete Juliano, N6QW 11/2023



Several years ago, I had a Ten Tec Triton II that I gifted to a new ham who was short on resources and had ZERO gear. When I had a chance to pick up another Triton II for the price of three Big Mac's @ MickieD's, I sprang into action.

Cosmetically the former one was a tad bit better, BUT this one works a lot better. This rig was perhaps one of the very early product line entries by Ten Tec into the ham market, with the LO generation a bit arcane.

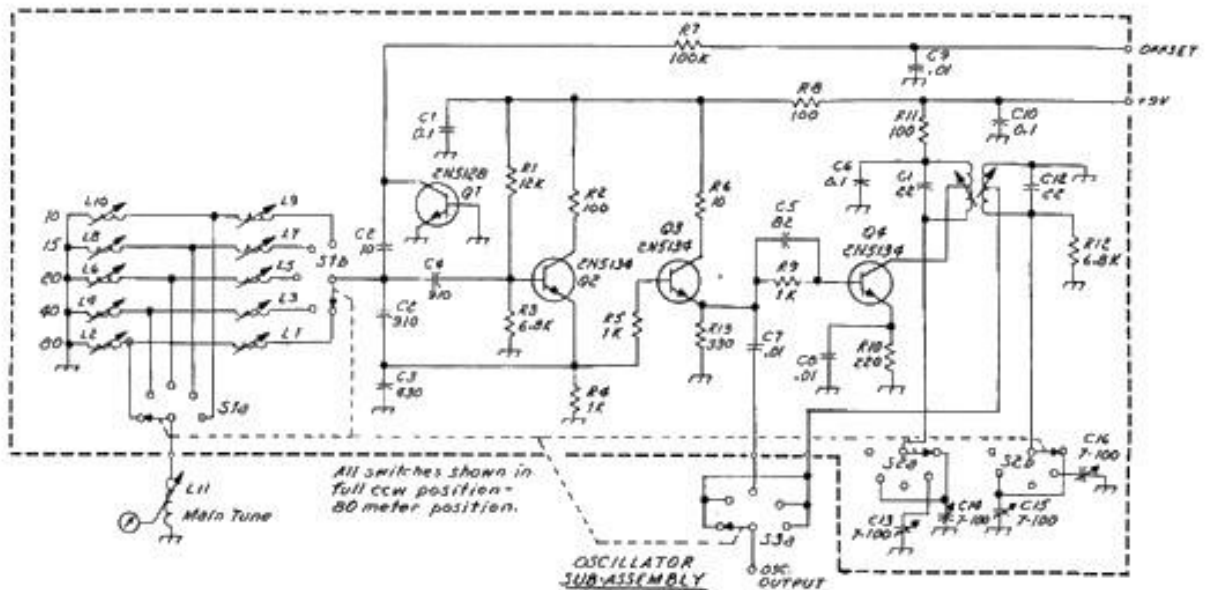

Essentially Ten Tec has a standard PTO (L11) and as the bands are switched, two inductors are switched across/with the PTO. One of the inductors sets the band edge and is directly connected in parallel with the PTO. The second inductor in effect is in series with the parallel combo and its purpose is to set the bandspread. That resulting signal is either used straight on through or doubles or is tripled.

On 75/80M the output range is in the 12-13 MHz region and on 40M the LO is in the 16MHz range. For 20M the LO is 5 MHz and for 15M back to the 12 -13 MHz range. Finally, for 10M it is 19 to 21 MHz. On the lower two bands the LO - BFO sets the operating frequency and on the upper three bands it is the LO + BFO. For instance, 10M has  $19 + 9 = 28$  MHz and  $21 + 9 = 30$  MHz. The frequency tripling sure makes for a touchy VFO.

For the lower four bands one dial scale (0 to 500) is used and for 10M a second scale (28 to 30). That was great in 1970 but today – it is like doing Brain Surgery with a Rusty Spoon!

What we are saying is that the Triton II is ripe for the addition of a Digital VFO. This change not only opens up the availability of a more precise AND accurate frequency readout, but also the stability factor opens the door for FT-8 with a Triton II. The Ten Tec Manual says you are close, if it is within +/- 2 kHz. Adjusting those inductors for the five bands and achieving the frequency accuracy goal is like going bald from pulling your hair out and also having to join AA.

Generating LO frequencies for these ranges is fairly straight forward if all you want to do is use the Triton II on SSB. But, by and large Ten Tec knew how to make a combo SSB/CW transceiver as the one I have, has a two-position Audio CW Filter, a unique Break In circuit and Offset Tuning. So certainly, with all of that clout you would want the CW capability as well and that is THE problem! But let's take a look at the Triton and see how it was designed and built.

The Triton II is a 100-watt SSB/CW Transceiver. Its brother, the Triton I is essentially the same but rated at 50 watts. Of note there is but a single Crystal in the BFO/Carrier Oscillator. Ten Tec used transistor switching to "ON" several Trimmer Caps so that the oscillating frequency is changed. On CW the Crystal is shifted to the center of the pass band of the 4-pole crystal filter. LSB involves a capacitor to shift the crystal frequency.

From the Receive Mixer the 9 MHz signal is passes through the 4-Pole Crystal Filter. Next Stop: IF Amplifier stage and thence on to the Product Detector and Low-Level Audio. The CW Filter if present is installed here.

I found it interesting that today I would build the Tx Rx Mixer with a DBM like ADE-1 and then steer the signals in bilateral fashion through that mixer. Amazing what 50 years of technology will do.

On the transmit side the SSB Generator board has the Carrier Oscillator, the Microphone Amplifier, the Balanced Modulator (CA3053) and the Crystal Filter all on one small board.

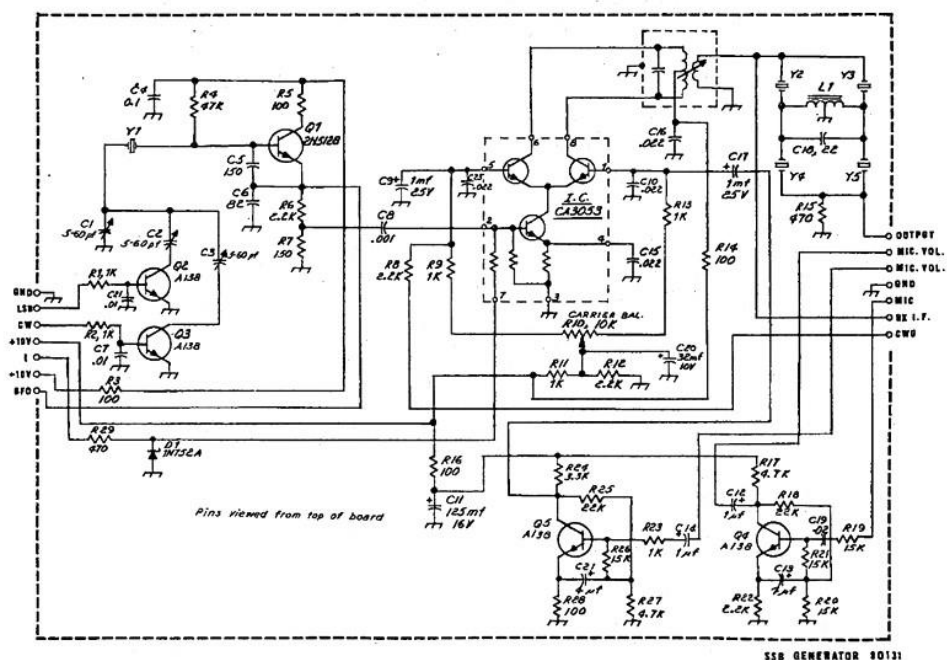

In the original Ten Tec Triton II design, a transistor, Q1, is connected and biased in such a way that it forms a PN junction and the junction capacitance can be changed simply by varying the voltage to the junction. (This is like a MV209 varactor tuning diode.) The PN Junction is attached to the PTO array via C2. When biased on, it becomes the Offset Tuning and when powered off (CW transmit it is off), No Offset.

My plan would be to bypass the internal VFO and inject the Digi-VFO signal into the board that contains the Rx and Tx Mixer. Following that is our next design challenge, the “how to do” CW with the Digi-VFO.

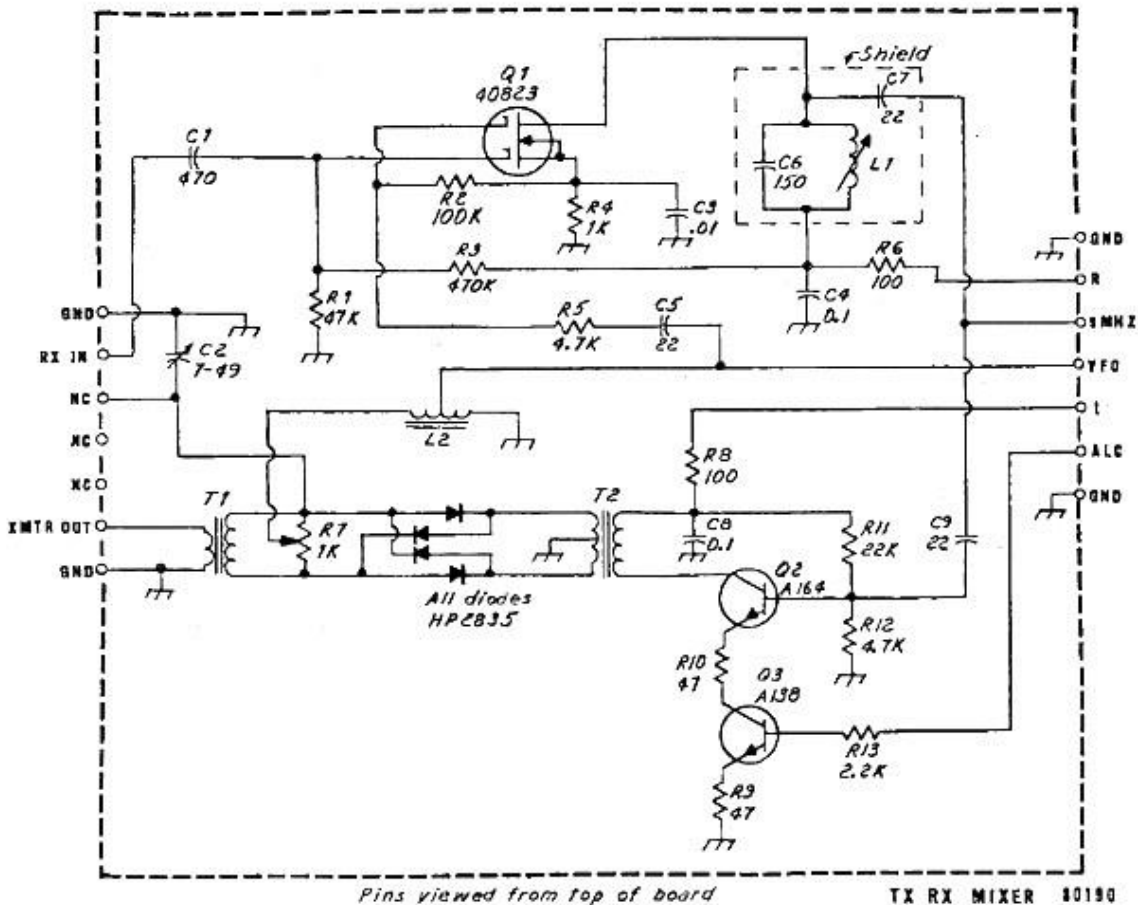

Along the right-hand side of this circuit module is the Pin Marked VFO. This is where the LO signal would be injected into this stage. Of note, that

signal feeds Gate 2 of the 40823 which is the Receiver Mixer and the output at C7 is the IF or 9 MHz also a Pin in that array. The VFO is also fed to what is a discrete (like homebrew) Double Balanced Mixer using at that time special HP hot carrier diodes (HP2835). On Tx a 9 MHz SSB from the filter is now fed onto the same pin that was the output for the Rx. Q2 is now turned on with the "T" voltage and thus our discrete DBM takes the 9MHz SSB and the VFO (LO) mixes them and outputs the results to at T1. Actually, there are Sum and Difference frequencies at T1. Subsequent Band Pass Filtering peels off the right values. ALC is applied at Q3.

In the earlier Triton II that I had, Q3 had no ALC which acts as a variable emitter resistor for Q2 thus NO transmit. The culprit was a blown 6.3 Volt light bulb which was in series with 12V DC and fed the ALC Board. Circuit constants set the ALC level. But as you "talked up" the bulb would light and the ALC level would change. The light bulb was not shown on the ALC module on the earlier schematic I had, but merely says ALC Light. I was fooled to thinking that it was Voltage Output to the Bulb. Instead, it was Voltage Input from the Bulb. The schematic in the current manual is right.

When in the CW mode with offset voltage is applied to the PN Junction and you tune in the signal with the offset control. When you key the radio for transmit, the Offset Voltage is removed and automatically the CW transmitted signal is shifted 750Hz.

I was not able to replicate the Ten Tec Offset directly and with my modification the on-board offset is defeated. That said I was able to create a fixed +10 KHz SSB offset for split DX operation. To turn off the offset and return to normal operation (SSB), a keypad Button (9) does that.

I am not a coder, so much of my time is spent in the cut and try process and I think I have something that works. Now before everyone gets terribly excited, again this does not have the variable Offset like Triton II.

But for the average CW guy this would be good enough for Straight Key Night.

To add to the functionality of my Digi-VFO and Controller, I use a Keypad and an Encoder. From the Keypad the radio can be up / down tuned as well selecting one of two step tuning ranges. But with encoder you have a choice of other step tuning ranges, like 100kHz.

In Keying the Triton II for CW, you actually key the Controller and a reed relay in the Controller then keys the transmitter. There is a small Delay built into the Arduino code so that you remove the offset for a pre-determined period of time which initially I have set at 5 milliseconds as we need that length of delay for our initial tests. Most likely for medium and low speed CW that delay is perfect. The Triton II is like QSK.

I have done some preliminary tests by just a quick flick to ground of the designated keying pin and the display and the transmit frequency changes so I have every reason to believe the rest will fall into place. Following are some shots of the display panel.

I should mention this is a typical development for me – you fix one thing and you find you broke two other things. So, the code has gone through many iterations. BUT this sojourn has taught me how to fix some things that have always been a problem in the past but today are clear as to the why and are now in the “fixed” pile.

The following is an excerpt from the Triton I/II manual regarding CW and it is as I suspected the CW Transmit signal is shifted automatically by 750 Hz (the trimmer that is engaged via a transistor switch on the SSB Generator board). The 750 Hz shift is picked to work with the CW Filter.

Two CW positions are indexed on the MODE switch, CW-1 and CW-2. The TRITON, as shipped from the factory, will receive signals in the CW mode only in the CW-2 position. The transmitter will function in both the CW-1 and CW-2 positions, however. As shipped, the bandwidth in the CW-2 position is identical with that in the SSB modes, that is, 2.5 kHz. When the Model 245 CW filter accessory is installed into the TRITON, the CW-2 position then provides a bandpass curve peaked at 750 Hz with reduced response on either side. In the CW-1 position, the full 150 Hz wide filter is connected into the circuit which provides very sharply attenuated skirts. CW-2 should be used when QRM is not a factor, when tuning to a desired received signal or when the signals on either side of the centered signal are to be monitored. CW-1 will greatly attenuate signals slightly removed in frequency from 750 Hz, eliminating adjacent channel QRM, and will also reduce the amount of QRN and annoying high frequency audio signals. In mobile operation, it will be found that the CW-2 position can be used for SSB reception with reduced high frequency ignition noise components. In the CW positions, the sidetone signal is fed into the audio system. Its level can be adjusted with the thumb potentiometer located through the access hole in the bottom plate. In CW, the transmitted frequency is automatically offset 750 Hz from the received signal. This compensates for the BFO beat note of the received signal and puts the transmitter exactly on the received frequency. 750 Hz was chosen as the offset to correlate with the center frequency of the Model 245 CW Filter. When the received signal is peaked on the S meter, the beat note will be 750 Hz.

The LOCK position of the MODE switch is used for system checks and SWR measurements. It energizes the transmitter on the CW frequency, in the key-down condition, but does not key the sidetone oscillator. The DRIVE control adjustment for CW operation can be made in the LOCK position, but the setting of this control does not necessarily hold for SSB transmissions. Microphone sensitivity, closeness of the mic to the lips and loudness of the speech all determine the DRIVE setting for SSB.





Normal Display for SSB



Display with a - 700Hz Offset.



Display with a +700 Offset

Some refinements here have been added as you look at the three photos you see in the upper Left Corner where it says "Rx" and that means it is receiving and "Tx" here means it is in transmit

When you Key the Controller the Rx changes to "Tx" and in the very upper Right-Hand Corner a custom LCD Character was created that fills in the whole LCD space (at 15,0) with Black. Thus, one side says Tx and the other is a filled in block. When the timing cycle is over, Then Tx goes back to Rx and the black block goes away.

The timing cycle lets you send code at a normal speed without constantly having the Transmitter return to receive. The High-Speed guys likely want a "0" time delay but given some relays are being used, maybe 5 -10 milliseconds delay is about the bottom end.

So please understand I am trying to create the CW functionality so you can do CW with the controller. If you are looking for a very sophisticated

CW break in and QSK arrangement my code will fall short. A knowledgeable coder likely can do that – but beyond my capabilities.

Some interesting thoughts and possibilities:

Add a second built in VFO so you could do split operation (a little complex with the 3X4 keypad and you might need a 4X4 pad).

A 5 or 10 kHz offset for use on SSB and then you could work those DX expeditions. I have set one of the Keypad buttons so on Transmit you are transmitting 10 Kilohertz up on SSB. Watch the Band edges!

I also had to deal with once you are in the Offset mode how do you return to normal operation. One key on the keypad is designated for that purpose as it removes information from the LCD, and resets the frequency so no offset is in the code. Thus 25% of the keys on the Keypad deal with Offsets.

Of note, TT builds circuits in modules and thus easy to service AND modify! The actual Triton II modifications would involve connecting to the LO Pin on the Tx Rx Mixer board (as was stated earlier) and running a chunk of coax to one of the RCA connectors on the back panel.

TT has brought out functions like External Linear Amp Keying, Sidetone, Phone Patch, PTT, etc. The Phone Patch connector seems like a good choice for repurposing to the external LO input. There is also a jack for +12V DC and the Key Jack which can be used “as is”. Bottom line you disconnect the internal LO from the Tx Rx Mixer and connect to the RCA Jack with RG -174U. The access is really easy inside the radio.

Also of note is that the Ten Tec Manual speaks to using the sidetone jack for keying a QSK amp like one of the 9500 Alpha’s. Appropriately, this was envisioned by TT that you might have to repurpose some of the jacks.

This documentation has been written over a several weeks' time span and what I said early on needed some rethought, re-evaluation and outright changing. Following are some of those exact items that fall into that category and for the most part will only be determined once the controller is installed and operated.

- I know that the Carrier Oscillator is shifted on CW and centered on the 4-Pole Crystal Filter Passband. Since CW is a panel mounted mode selection, what does that do to the received signal. Is the need for the Offset Control to shift the VFO to compensate for where the Carrier Oscillator is placed on CW? This is easy to check with the Triton II in its unmodified state. The results of this test could/will impact what I have done with the Offset. Might be time to RTFM.
- The Triton II has a non-adjustable time delay so as you key, the transmitter changes state for every key stroke. Thus, it is turned off/on with each dot. My Controller has the same functionality with the 5ms delay. Their delays will have to be synchronized otherwise at the end of a timing period one might be off while the other is still engaged. To modify The Triton II so that my controller is the "Only" delay might cause issues with other timing functions and is a step too big for a simple implementation by me. Synchronization seems like less of a science project.
- Not considered but how about using some of the Arduino Analog capabilities to adjust the Power Output of the Triton II from the keypad. This would require an internal modification to the Triton II and most likely a shift to the 4X4 Keypad. I would also enjoin a shift to the Mega 2560 MCU. I purchased a Mega 2560 with a plug In Color TFT and this array would really "spiff up" the what can be displayed. Microchip make a software controlled 10K Ohm Potentiometer. With a Mega 2560 I see possibilities for controlling

the Audio Volume and Power Output since these are already controlled with a potentiometer internal to the radio.

- When you are up to your “butt” in alligators it is hard to focus on that the objective was to drain the swamp. It is best to think of this project in phases. The 1<sup>st</sup> is to get a Digital VFO installed and operational with SSB. That needs to be fully evaluated before moving to the CW side of the coin. We also must ensure that what we do in CW doesn't kill the SSB functionality. The next step would be the other opportunities just mentioned (volume and power output).

## The Final Result

On December 10<sup>th</sup>, 2023 I took the plunge and connected the controller to the Triton II. Boom! It works and better than I expected. I made a video of the initial test and the link below takes you to that video.

<https://youtu.be/su8gFUnnJEA>

Some observations that I will now go back and refine. The “#” was intended for CW operation. It is not needed as putting the Triton II in the CW1 or CW2 takes care of the OFFSET on transmit. This Keypad button could now be set up for a -10kHz split and the “\*” button for + 10kHz split.

The slow tuning rate default might cause us to change the startup frequencies for 15M to 21.3 MHz and for 10M to 28.4 MHz. I have also built some time delays into the keypad tuning rate which I will relook to see if we can slew faster with the keypad

The Triton II / Digital Controller has been operated in transmit of 10, 15 and 40M and all signal reports were good! Next, I want to test the operation on 20 Meters. That was done with great success

The next bit of attention needs to be on peaking and aligning the receiver. I noted that on an earlier Triton II that it seemed deaf and a tweak of the trimmer in the RF amp stage perked things up. But this time I want to follow the alignment procedure. Most of the rest of the transceiver seems OK and likely if I do anything other than the RF amp stage –we get the usual –it doesn't work now.

Back to the transmitter and power output. I see 85 or so watts on 80-15M and only 60 watts on 10M. With the original Triton II PTO those values were close to 100 watts on 80-15 and a bit lower on 10M. Right now, I have a 0.47Ufd coupling cap between the Si5351 and the LO input pin. I may try raising that to close to 1Ufd and see if that perks up the power. You cannot direct connect the Si5351 to the LO input pin as the power really drops off. I suspect because the LO Input direct feeds the DGM and the DBM that the cap is needed. Indeed, changing that cap to 0.94 Mfd. raises the output to 100 watts on 80-15 and on about 75-80 Watts in 10M.

Of note I experienced the use of thin gage aluminum to build a case for the project. This material is easily bent in a vise and with a rubber mallet can be “hemmed over” for added strength.

I find it interesting that many of my initial thoughts about how to do this were changed once I got something built. It is the old continuous improvement thing. The second one will be easier

Pictorially the controller looks like the diagram below.

